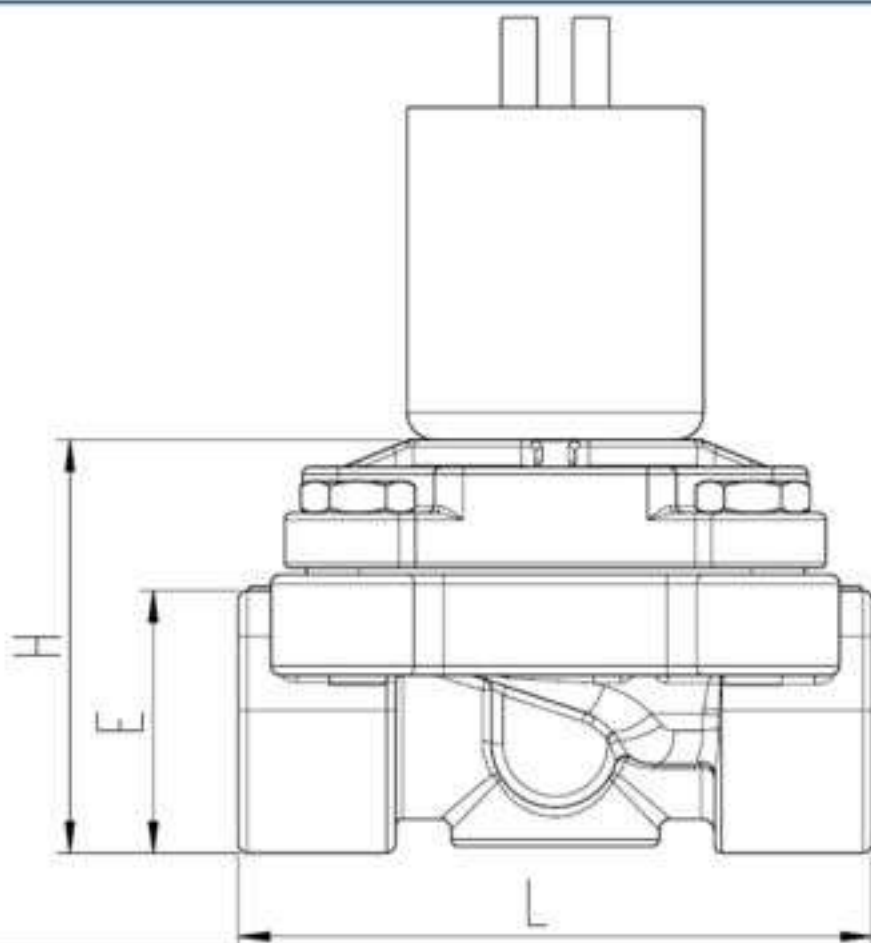
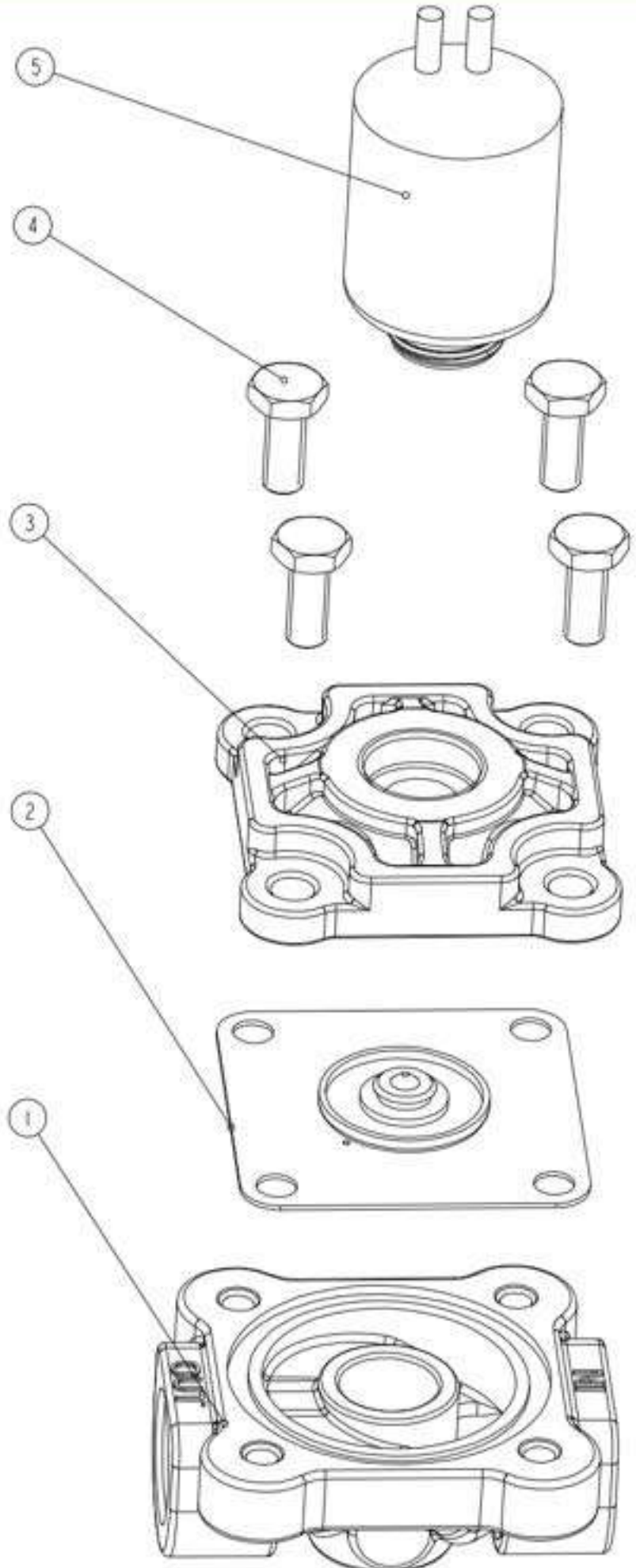

## DSF-1/2-FF PILOT TYPE SOLENOID VALVE

DSF-1/2-FF PILOT TYPE SOLENOID VALVE				
<b>Product Picture</b>	<b>Dimension (unit: mm)</b>			
				
<b>Product Usage</b>	<b>Specification</b>	<b>L</b>	<b>H</b>	<b>E</b>
<p><b>Economical Irrigation Valve</b> designed primarily for the residential and light commercial use, and it features solid construction, convenient operation and reliable performance. For each type, they can be assembled our irrigation solenoids( S391 series plastic shell &amp; S392 series metal shell), alternative voltage: 12/24 VDC, 12/24 VAC, 4-9 VDC latch &amp; 6-40 VDC latch (special requirements can be customized)</p>	3/8NPT VALVE	70.6(mm)	46(mm)	27.9(mm)
	1/2NPT VALVE	70.6(mm)	46(mm)	27.9(mm)
	3/4NPT VALVE	70.6(mm)	57(mm)	37.7(mm)
<b>Construction</b>	<b>Performance Feature</b>			
	<p>1、 Valve body made of Aging-proof Corrosion-Resistant Reinforced Nylon for the long life duration.</p>			
	<p>2、 Rugged synthetic rubber diaphragm provide the lead-proof seal.</p>			
	<p>3、 High-flow, low-friction-loss design.</p>			
	<b>NO</b>	<b>Major Parts</b>	<b>Material</b>	
	1	Valve Body	Reinforce PA66	
2	Diaphragm	Component		
3	Cover	Reinforce PA66		
4	Screw	Stainless steel 304		
5	Solenoid			
<b>Specification</b>				
<b>Connection:</b>		Optional		
<b>Water Pressure:</b>		10~150PSI		
<b>Water Flow:</b>		12~50L/min		
<b>Voltage: 24VAC 60HZ</b>		Optional		